

MP STEP

Escalators and moving walks

Adaptability and optimum performance

The range of MP STEP escalators and moving walks is one step beyond technology, efficiency and adaptability. A wide range of possibilities ensures the suitability of every choice, no matter what the real conditions of any situation are. Space, passenger traffic and usage conditions stop being limits and become our indicator to determine a better choice. Moreover, modular design optimizes installation and enjoyment of the product, thanks to its excellent response capacity to project specifications.



A system offering very different possibilities with excellent common characteristics: reliability, comfort and optimum performance are the base for the success of any product of the MP STEP range.

Due to our philosophy of excellence and continuous improvement, all our products comply with the European Regulation EN115 and other international codes, such as National Quality & Technology Supervision Bureau (P.R.China) and Russia Mine & Industry Technology Supervision Bureau.

IDEAS THAT MAKE YOU GO FORWARD





A KIND OF PRODUCT FOR ANY NEED

Range of MP products



A STEP FURTHER IN ADAPTABILITY

FOR PUBLIC BUILDINGS

COMMERCIAL. MP COLINA

Escalators for shopping malls, big stores, supermarkets, hotels, office buildings, museums, hospitals and airports.

HEAVY DUTY. MP SIERRA

Escalators for subways and railway stations mainly.

TROLLEY. PONT | PONT F

Inclined moving walks for shopping malls, big stores, supermarkets and similars.

LONG WAY. PONT H

Horizontal moving walks for airports and long-distance passenger transit.

	COLINA	SIERRA	PONT	PONT F	PONT H
Installation	Indoor/Outdoor	Indoor/Outdoor	Indoor/Outdoor	Indoor/Outdoor	Indoor/Outdoor
Working hours (hours/day)	16	24	16	16	16
Inclination (°)	30°/35°	30°/35°	10°,11°,12°	10°,11°,12°	0°,6°
Speed (m/s)	0,5	0,5 / 0,65 (if 30°)	0,5	0,5	0,5
Capacity (persons/hour)	up to 7300	up to 7300	up to 6000	up to 6000	up to 6000
Step width (mm)	600/800/1000	600/800/1000	800/1000	800/1000	800/1000/1200/1400
Vertical rise range	7.5m (30°) / 6m (35°)	12m (30°) / 6m (35°)	7 m	7 m	10-100 m

NEEDS BECOMING SOLUTIONS



SECURITY AND OPTIONS

Escalators and moving walks

Do you already know the most suitable model for you? Complete it with a high number of options that optimize the performance, safety and aesthetics of your product even more.

OPTIONS

- Safety brake on main shaft
- VVVF
- Auto-lubrication system
- Balustrade / skirt lighting
- Traffic lights
- Handrail speed sensor
- LCD fault display
- Auto-starting (photocells or contact mat on landing)
- Telecontrol
- Coloured handrail
- Truss cladding: stainless steel or painted plate
- Preparation for outdoor (waterproof screws, Oil-water separator, lower pit float contact...)

SAFETY ELEMENTS

- Drive chain contact (1)
- Step chain contact (2)
- Handrail entrance contact (4)
- Comb plate contact (4)
- Skirting contact (4)
- Step sag contact (2)
- Step missing contact (2)
- Landing plate contact (2)
- Emergency pushbuttons
- Step gap lighting
- Step yellow frame
- Phase relay
- Other safety elements
- Anti-reverse function (O)
- Step anti-uptrust contact (O)
- Motor overheat protection (O)

(O) Optional

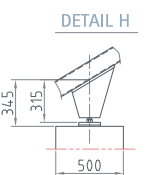
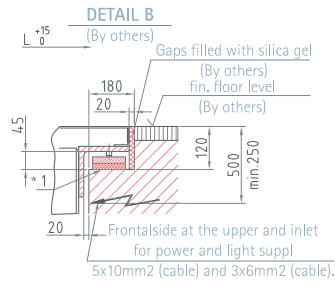
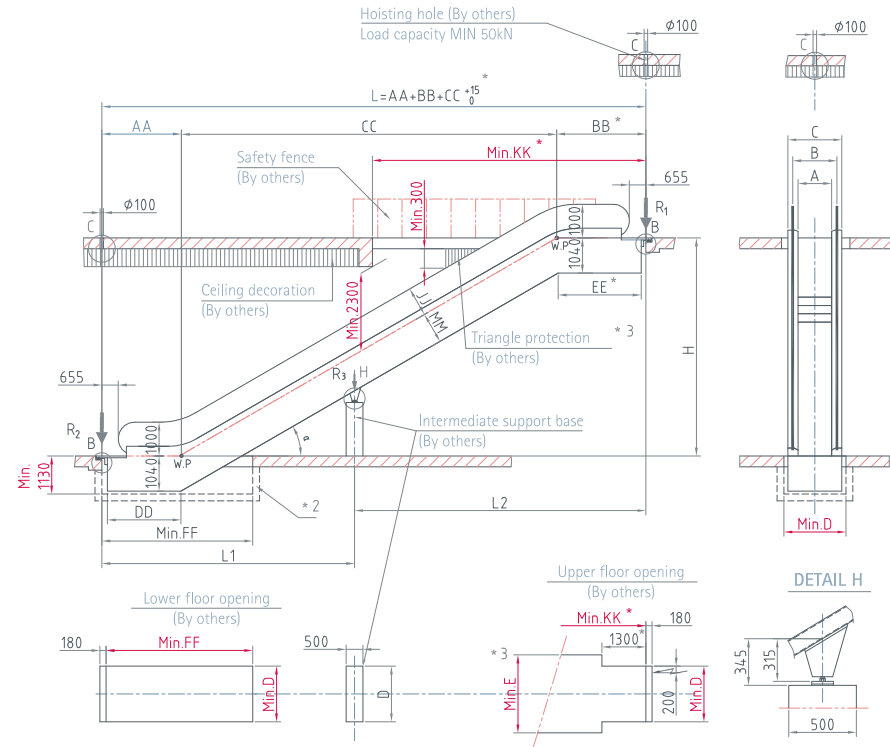

VERTICAL/INCLINED BALUSTRADE

A	600	800	1000
B	837	1037	1237
C	1145	1345	1545
D	1200	1400	1600
E	1850	2050	2250

TYPE	a	AA	BB	CC	DD	EE	FF	JJ	KK	MM
MP COLINA 302	30°	2195	2564	Hx1732	2205	2482	4200	870	7900	940
MP COLINA 352	35°	2229	2648	Hx1428	2352	2455	4000	850	7100	960
MP COLINA 303	30°	2595	2964	Hx1732	2605	2882	4600	870	8300	940
MP COLINA 353	35°	2629	3048	Hx1428	2752	2855	4400	850	7500	960

COLINA

Notes:

1. Mark*: Mark*1: Supports need to be in true level. Mark*2: If there is pit, this need to be water proof and smooth. Mark*3: If dimension E can not be guaranteed, a guard acc EN115 must be provided as shown.
2. According to EN115, the entrance of bothing landing must have enough area to facilitate the traffic flow.
3. Dimensions with mark * should be extended 440 mm in case 600mm step or double drive. If VVVF is included, extension will be always 500mm.
4. Intermediate support is required in case of horizontal distance L over 15m. please contact us.
5. All dimension refer to finished dimension is in mm.

A	Reaction Force (kN)	
	Without intermediate support	With one intermediate support
600	R1= 3.4xL+15.5	R1=3.4xL2+11.5
	R2=3.4xL+10	R2=3.4xL1+4.5
800	R1=3.75xL+17	R1=3.75xL2+12
	R2=3.75xL+11	R2=3.75xL1+4.7
1000	R1=4.2xL+18.5	R1=4.2xL2+12.5
	R2=4.2xL+11.5	R2=4.2xL1+4.9
		R3=3.4xL+3.5
		R3=3.75xL+4
		R3=4.2xL+4.5

Note. 1.L, L1,L2 are in meters

SIERRA

Notes:

1. Mark*: Mark*1: Supports need to be in true level. Mark*2: If there is pit, this need to be water proof and smooth. Mark*3: If dimension E can not be guaranteed, a guard acc EN115 must be provided as shown. If VVVF is added, the extension will be 500 mm.
2. According to EN115, the entrance of bothing landing must have enough area to facilitate the traffic flow.
3. Dimensions with mark * should be extended 470 mm in case 600mm step or double drive. If VVVF is included, extension will be always 500mm.
4. Intermediate support is required in case of horizontal distance L over 15m. please contact us.
5. All dimension refer to finished dimension is in mm.

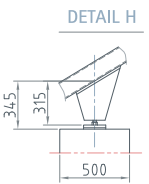
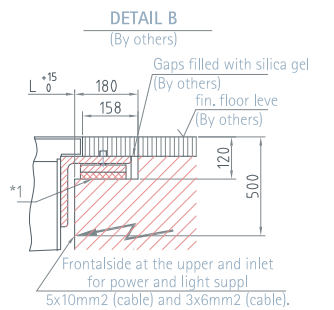
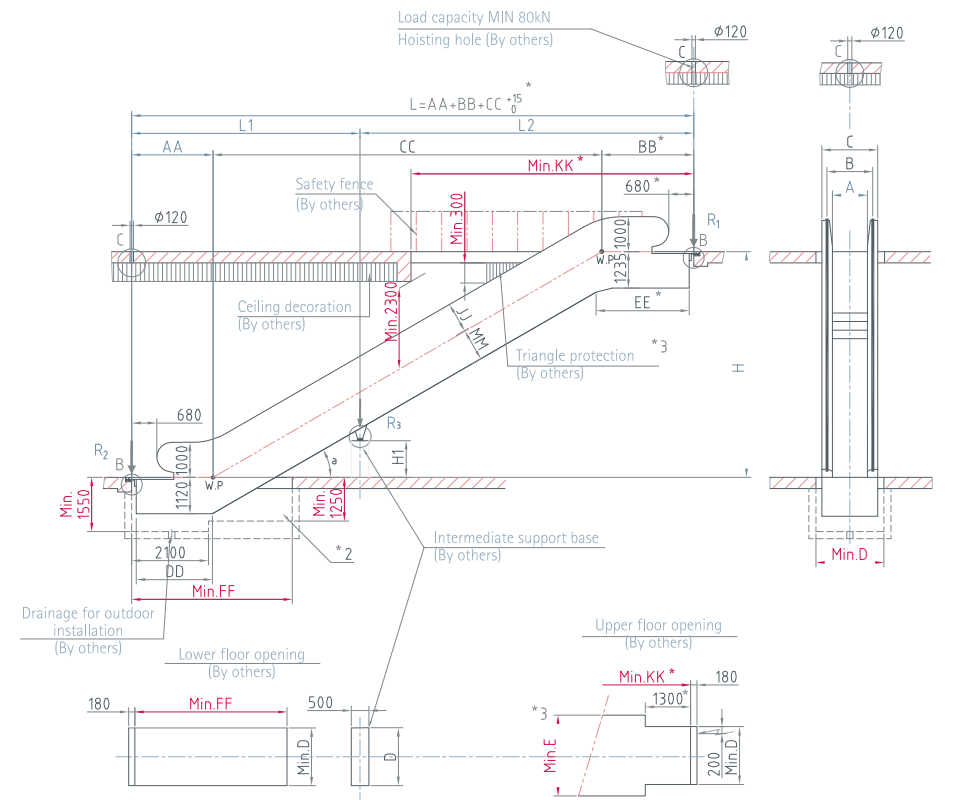

A	Reaction Force (kN)	
	Without intermediate support	With one intermediate support
600	R1=4.05xL+16.5	R1=4.05xL2+14
	R2=4.05xL+8.5	R2=4.05xL1+7
800	R1=4.45xL+17	R1=4.45xL2+16
	R2=4.45xL+9.5	R2=4.45xL1+7.5
1000	R1=4.95xL+19.5	R1=4.95xL2+17.2
	R2=4.95xL+10.5	R2=4.95xL1+8.3
		R3=4.2xL+10
		R3=4.7xL+11
		R3=5.2xL+11.3

Note. 1.L, L1,L2 are in meters.
2. L1 and L2 do not exceed 15m

VERTICAL BALUSTRADE

A	1400	800	1000
B	837	1037	1237
C	1195	1395	1595
D	1270	1470	1670
E	1910	2110	2310

INCLINED BALUSTRADE

A	600	800	1000
B	910	1110	1310
C	1195	1395	1595
D	1270	1470	1670
E	1910	2110	2310

TYPE	a	Upper radius	AA	BB	CC	DD	EE	FF	JJ	MM	KK
MP SIERRA / PIRINEO 302	30°	1500	2231	2598	Hx1.732	2370	2815	4530	870	1060	8000
MP SIERRA / PIRINEO 303	30°	1500	2631	2998	Hx1.732	2770	3215	4930	870	1060	8400
MP SIERRA / PIRINEO 304	30°	1500	3031	3398	Hx1.732	3170	3615	5330	870	1060	8800
MP SIERRA / PIRINEO 352	35°	1500	2266	2682	Hx1.428	2505	2780	4420	850	1080	7200
MP SIERRA / PIRINEO 353	35°	1500	2666	3082	Hx1.428	2905	3180	4820	850	1080	7600
MP SIERRA / PIRINEO 303	30°	2700	2863	3283	Hx1.732	3000	3500	5160	870	1060	8800
MP SIERRA / PIRINEO 304	30°	2700	3263	3683	Hx1.732	3400	3900	5560	870	1060	9220

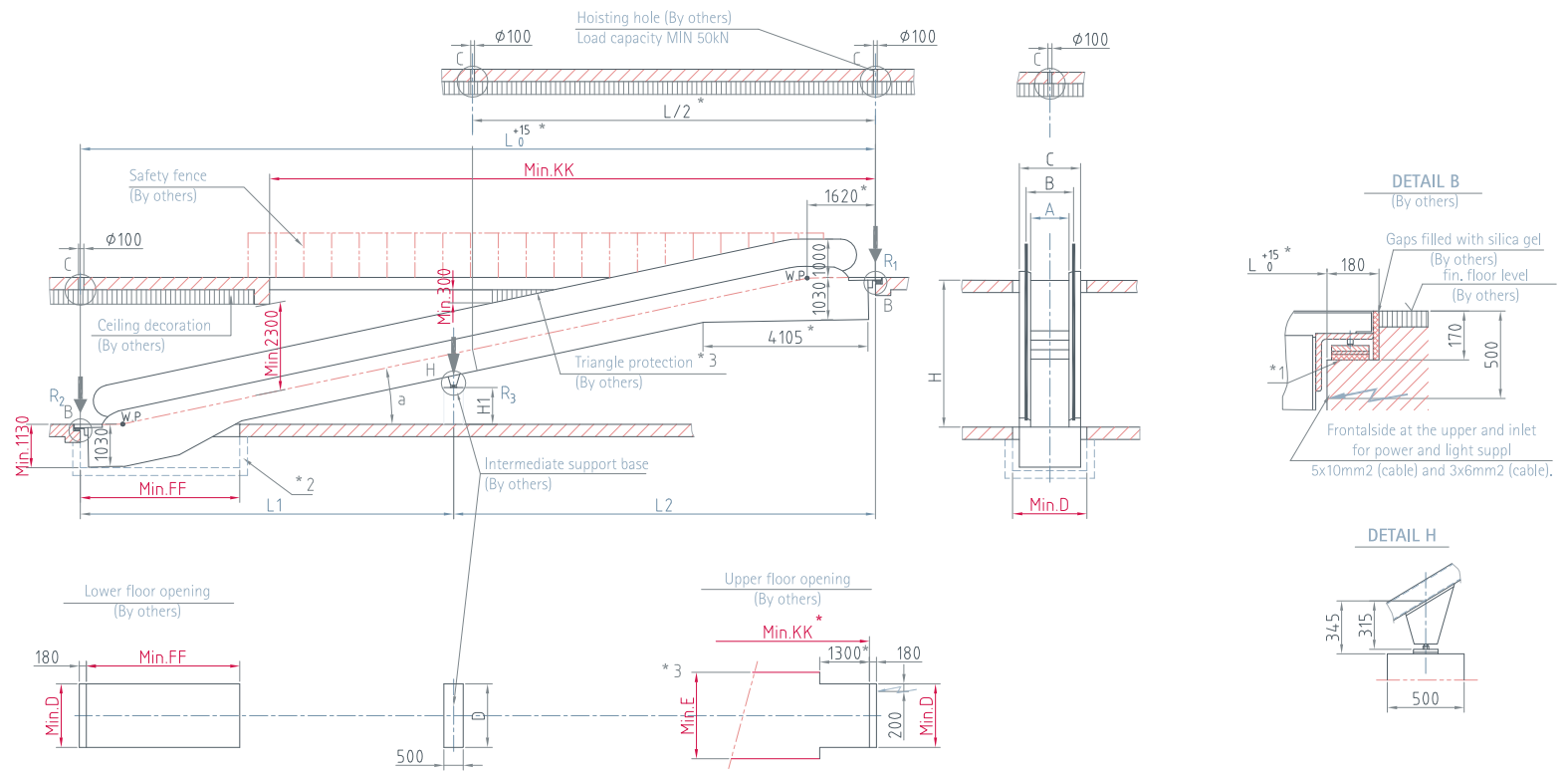

A	Reaction Force (kN)
800	$R1=3.45xL2+14$
	$R2=3.45xL1+7$
	$R3=4xL+16$
1000	$R1=3.85xL2+15.5$
	$R2=3.85xL1+7.5$
	$R3=4.5xL+17$

A	800	1000
B	1037	1237
C	1345	1545
D	1400	1600
E	2050	2250

TYPE	a	L	KK	FF
MP PONT 10	10°	HX5.671+2650	17700	4490
MP PONT 11	11°	HX5.145+2555	16700	4230
MP PONT 12	12°	HX4.705+2475	15800	3980

Note. 1.L, L1,L2 are in meters.
 2. L1 and L2 do not exceed 15m.
 3. Applicable in case of one intermediate support.

PONT

- Notes:
- Mark*
 Mark*1: Supports need to be in true level
 Mark*2: If there is pit, this need to be water proof and smooth
 Mark*3: If dimension E can not be guaranteed, a guard acc EN115 must be provided as shown (by others).
 - According to EN115, the entrance of bothing landing must have enough area to facilitate the traffic flow
 - All dimension refer to finished dimension is in mm
 - The intermediate support base can be made by concrete or metallic structure (By others).
 - Dimensions with mark * should be extended 500 mm in case double drive or VVF are included.

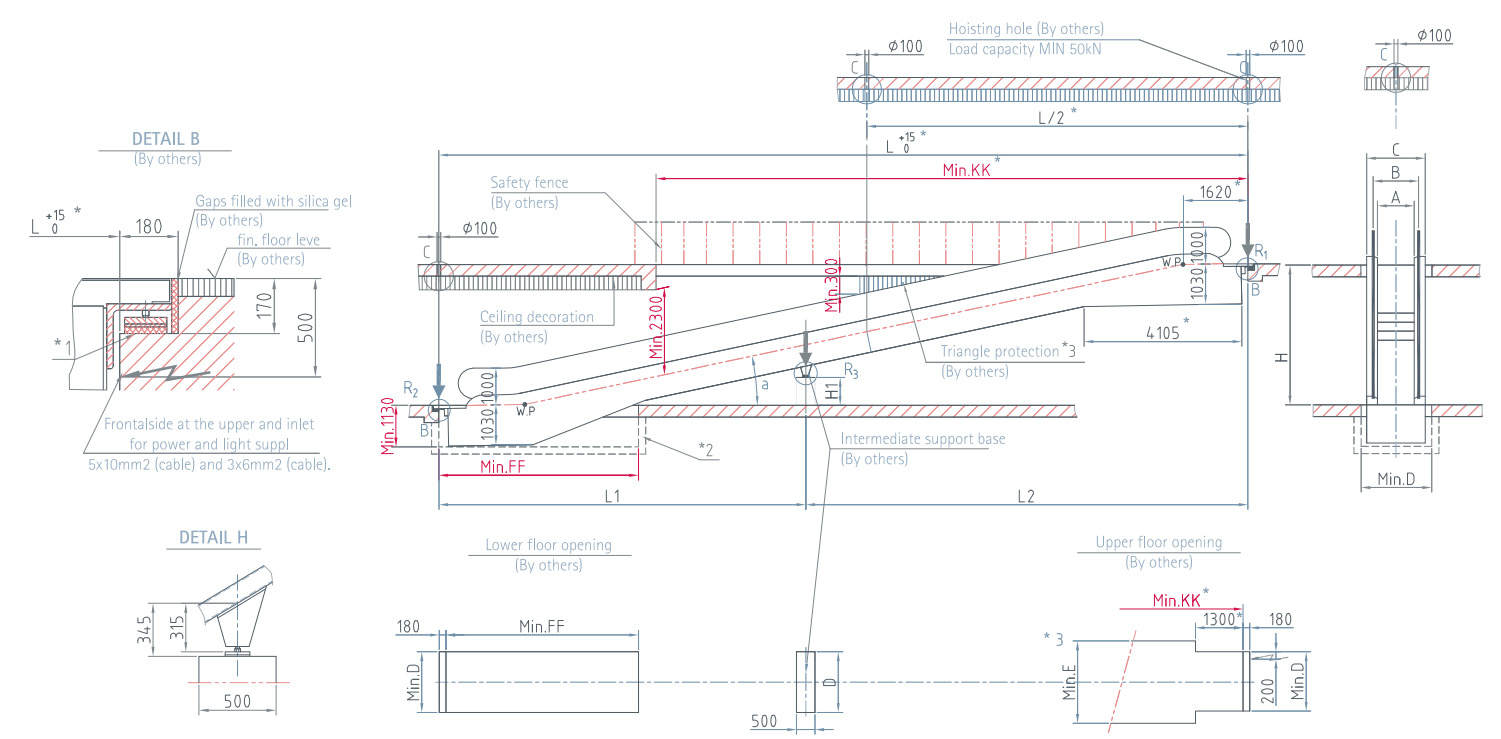

PONT F

- Notes:
- Mark*
 Mark*1: Supports need to be in true level
 Mark*2: If there is pit, this need to be water proof and smooth
 Mark*3: If dimension E can not be guaranteed, a guard acc EN115 must be provided as shown (by others).
 - According to EN115, the entrance of bothing landing must have enough area to facilitate the traffic flow
 - All dimension refer to finished dimension is in mm
 - The intermediate support base can be made by concrete or metallic structure (By others).
 - Dimensions with mark * should be extended 500 mm in case double drive or VVF are included.

A	800	1000
B	1037	1237
C	1345	1545
D	1400	1600
E	2050	2250

TYPE	a	L	KK	FF
MP PONT F 10	10°	Hx5.671+3945	17700	5740
MP PONT F 11	11°	Hx5.145+3755	16700	5480
MP PONT F 12	12°	Hx4.705+3595	15800	5230

A	Reaction Force (kN)
800	$R1=3.45xL2+14$
	$R2=3.45xL1+7$
	$R3=4xL+16$
1000	$R1=3.85xL2+15.5$
	$R2=3.85xL1+7.5$
	$R3=4.5xL+17$

Note. 1.L, L1,L2 are in meters.
 2. L1 and L2 do not exceed 15m.
 3. Applicable in case of one intermediate support.

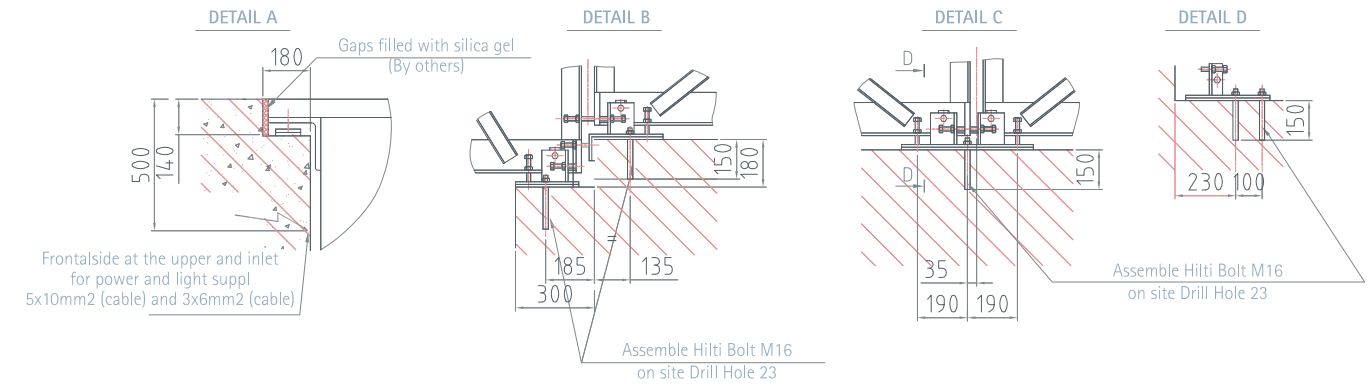
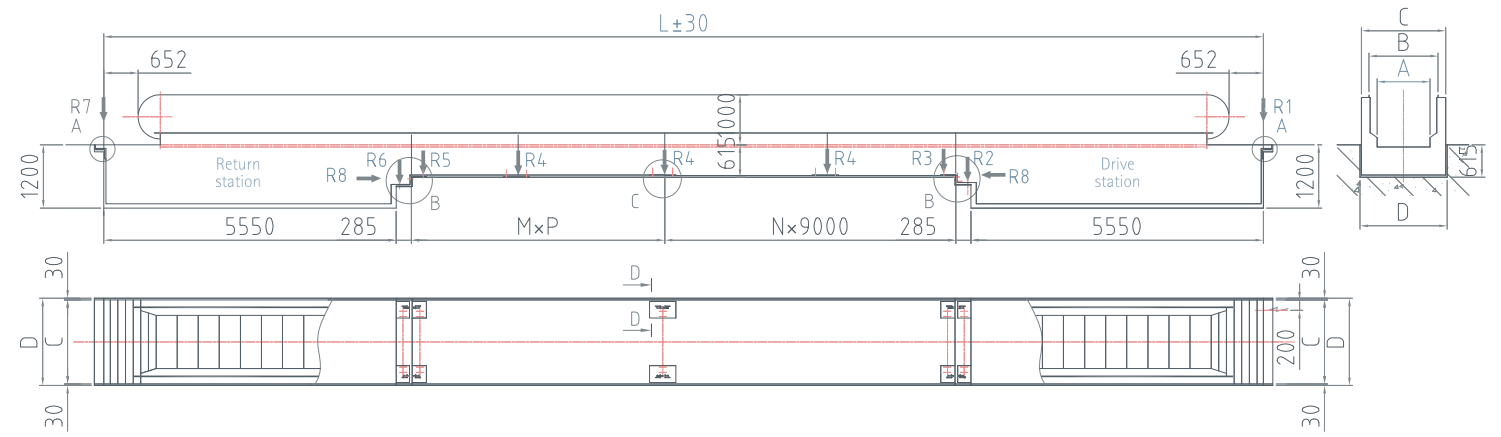

PONT H

- Notes:
1. Supports need to be in true level.
 2. If there is pit, this need to be water proof and smooth.
 3. According to EN115, the entrance of bothing landing must have enough area to facilitate the traffic flow.
 4. All dimension refer to finished dimension is in mm.
 4. The intermediate support base can be made by concrete or metallic structure (By others).
 5. Dimensions with mark * should be extended 500 mm in case VVVF is included.

A	1400	1200	1000
Reaction Force			
R1	45kN	38kN	31kN
R2	28kN	25kN	22kN
R3	70kN	62kN	54kN
R4	108kN	95kN	82kN
R5	70kN	62kN	54kN
R6	27kN	24kN	21kN
R7	43kN	36kN	29kN
R8	45kN	40kN	kN35

VERTICAL BALUSTRADE

A	1400	1200	1000
A	1400	1200	1000
B	1637	1437	1237
C	1995	1795	1595
D	2055	1855	1655

INCLINED BALUSTRADE

A	1400	1200	1000
A	1400	1200	1000
B	1637	1510	1310
C	1995	1795	1595
D	2055	1855	1655

A	1400	1200	1000
Power			
Max. length (m)			
5.5 kW	31	32	36
8 kW	43	45	51
11 kW	58	60	68
15 kW	71	81	92



FORWARD
IN ALL DIRECTIONS

PURE TECHNOLOGY IN MOTION

WAYS OF RUNNING

Escalators and moving walks

Our escalators and moving walks add a new dimension to the concept of moving forward. A wide and full range of products, capable to adapt to very specific needs as to functionality. Moreover, the potential of the saving system exceeds all expectations. Resource efficiency and optimization have never been so united.

Saving system	LOW TRAFFIC	MEDIUM TRAFFIC	HIGH TRAFFIC	WEAR AND TEAR
SIN SISTEMA	0	0	0	High
RL[PH]	10	30	40	Medium
RP[PH], RP[CP]	15	45	65	Medium
RLP[PH], RLP[CP]	15	40	60	Low

RL - Rated-low
RP - Rated -Stop
RLP - Rated-low-Stop

[PH] - Photocells
[CP] - Contact pressure on platform

■ Not recommended
■ Good performance
■ Optimum performance

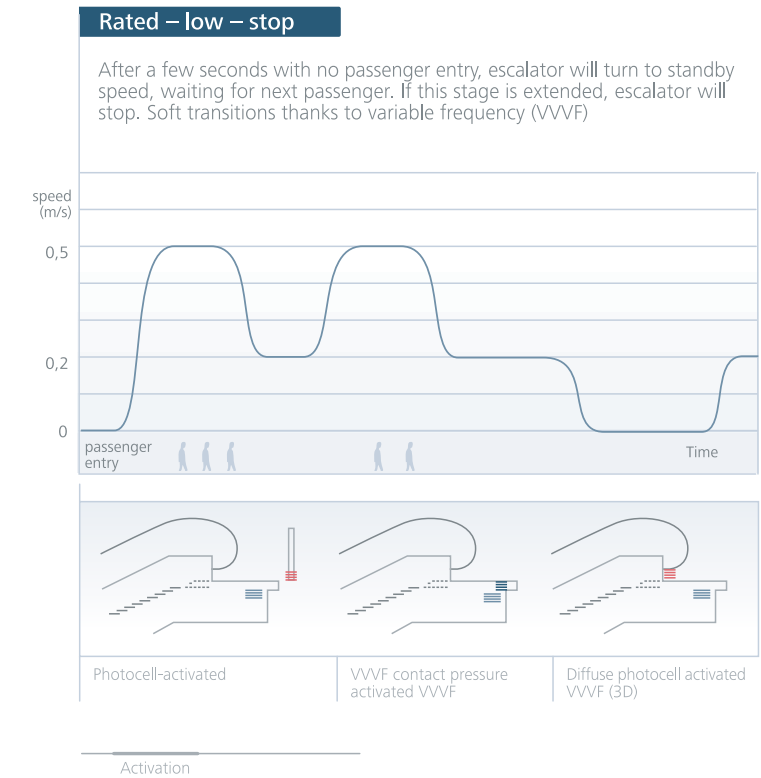
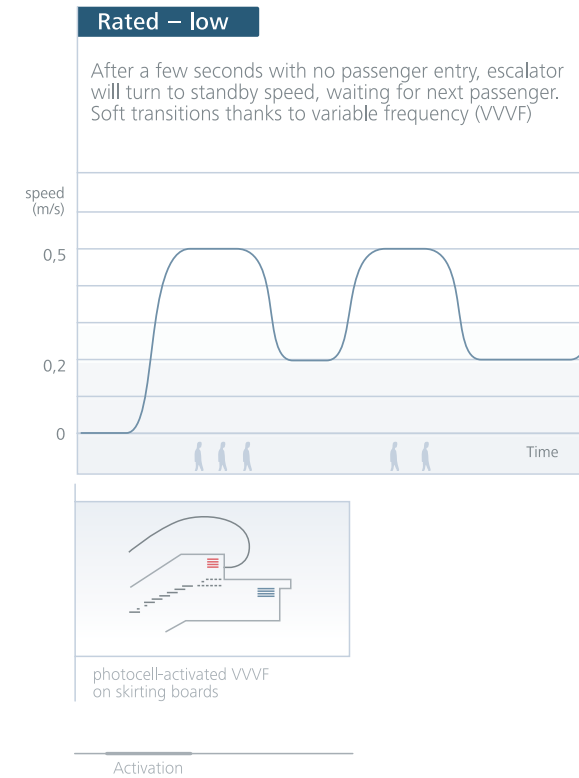
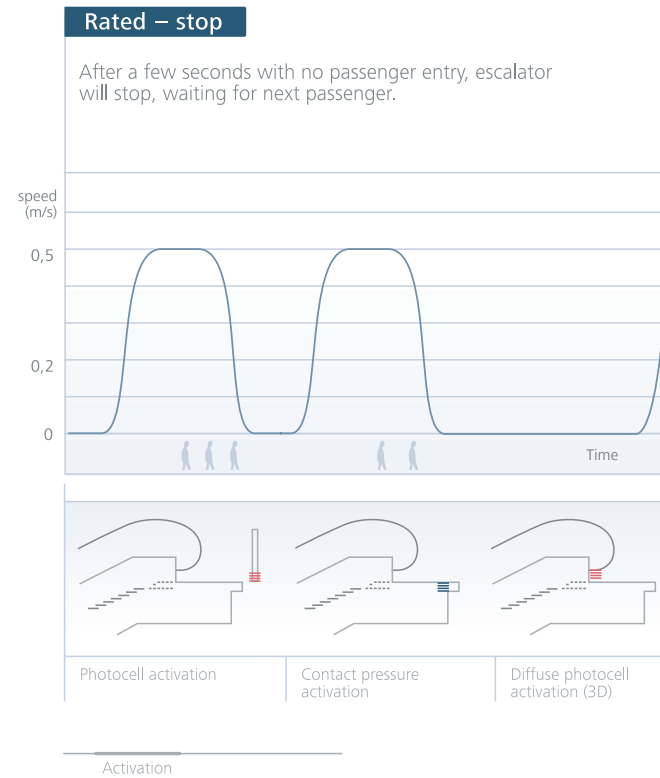

LEADERSHIP AND QUALITY WORLDWIDE

REFERENCES

The MP STEP range perfectly adapts to very different requests and needs. A great number of successful projects confirm it.



Integration

The efficiency of MP STEP products helps us offer you solutions fully integrated with the environment.

MP STEP
Mercado de Colón
Valencia, Spain.

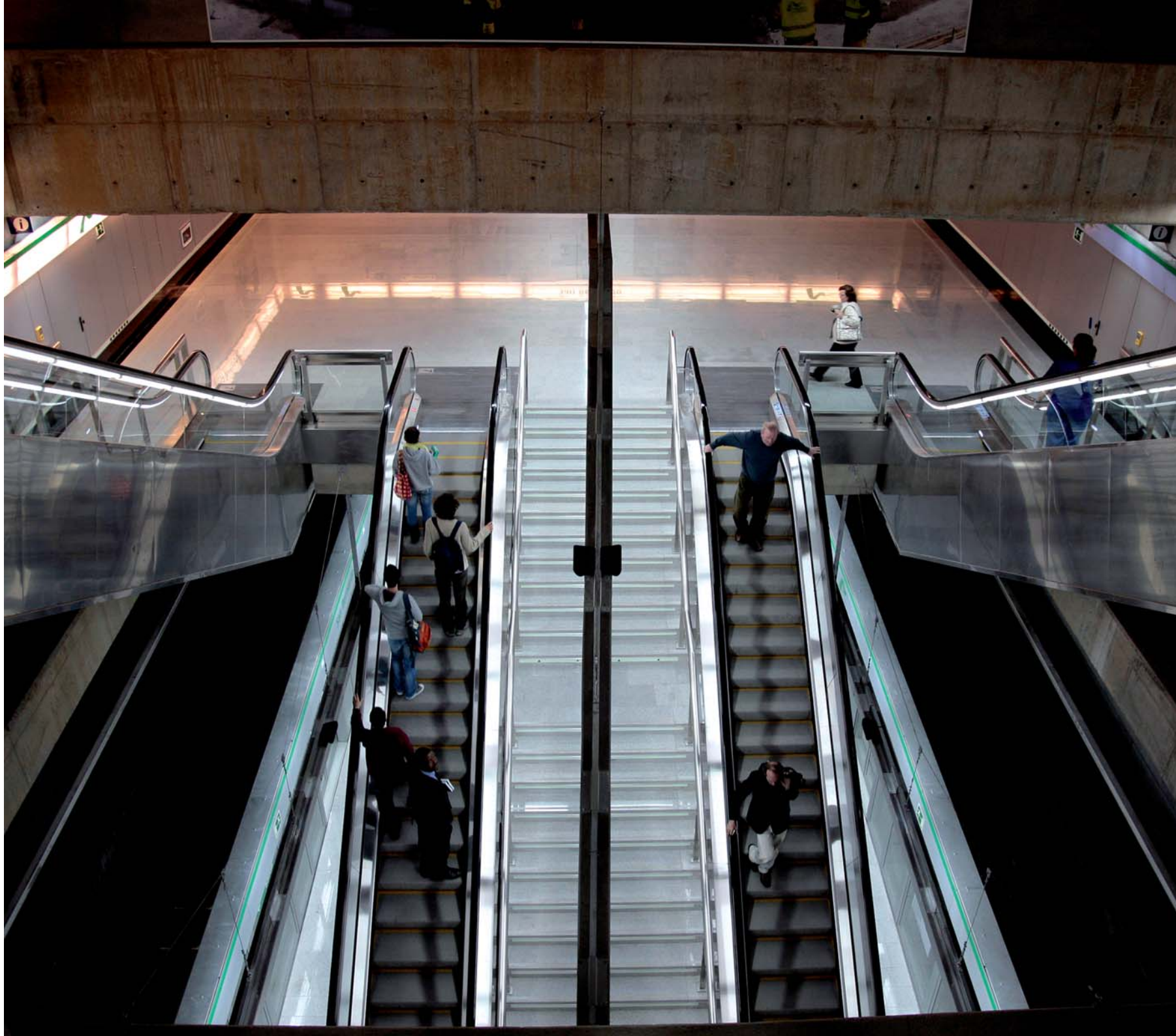

Performance

The number of passengers per hour is a fundamental parameter when choosing one of our products. The products of our range are able to carry very high traffic flows. Their performance is excellent in demanding conditions, such as in an airport or a subway station.

MP STEP
Seville metro,
Seville. Spain.

MP STEP
Poznan Airport,
Poznan. Poland.

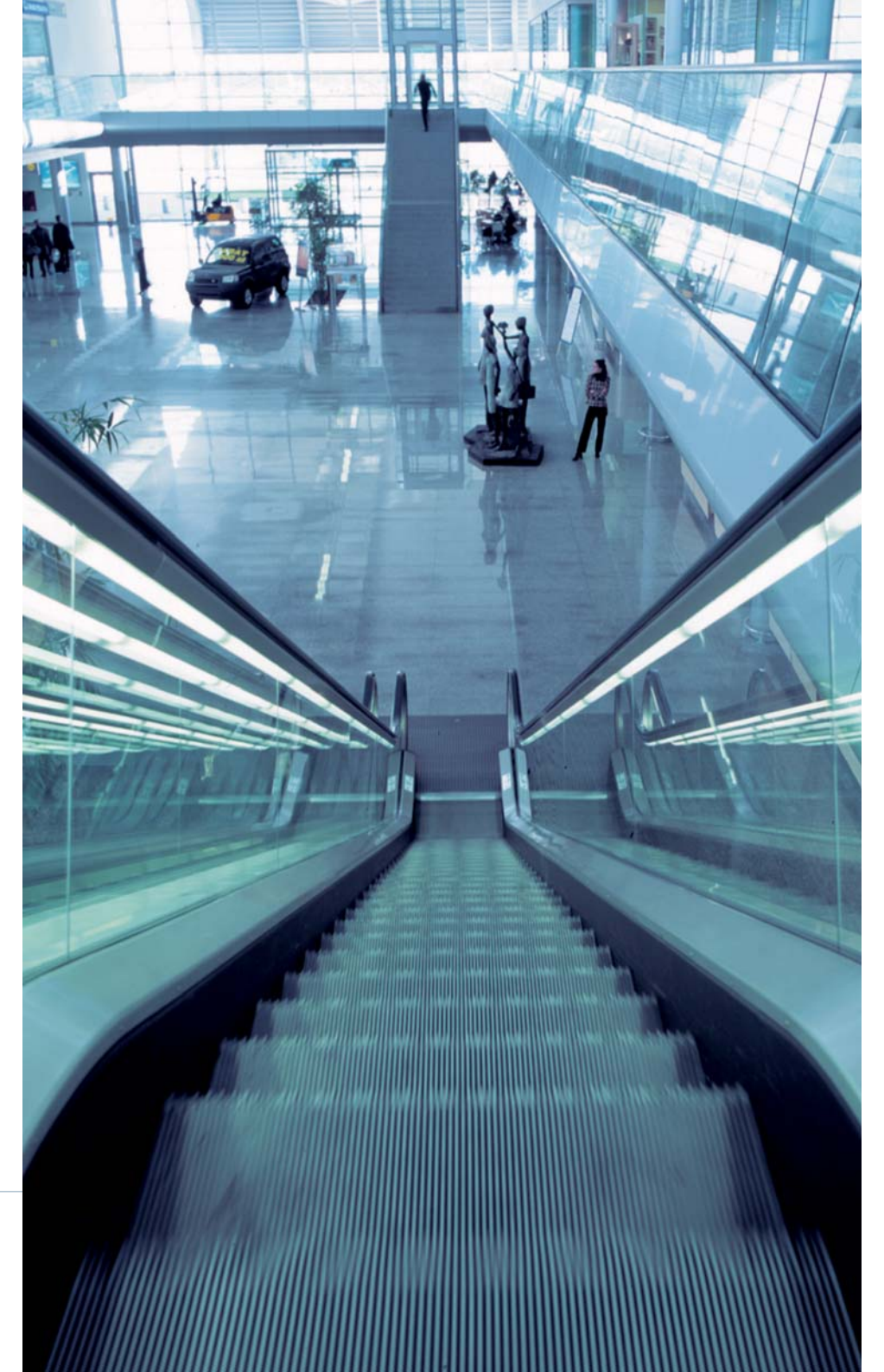



Adaptability

The benefits of the MP STEP range expand to more products. Every project is valued as a whole, enabling us to combine different solutions of elevation with perfection. A team vision pursued in the global development of the project too, from the idea to maintenance.

MP STEP
Merkamueble.
Barakaldo - Biscay, Spain.

